

ANCHORING DEVICES

Saddle Clip

A special bent-clip type fastener for removable bar grating panels, available in aluminum, stainless steel and galvanized steel.

Note: Cross bars may need to be snipped in the field to facilitate placement of saddle clips.

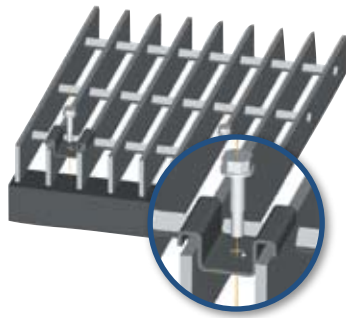

Lug

A plank lug inserted then tack welded between flanges, can serve as an ideal anchor block for plank grating.

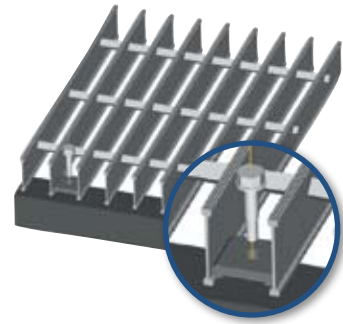

Channel Frame

A special C-channel frame fastener system used in conjunction with welded anchor blocks between bearing bars. The fabricated frame is held in place by TEK screws that are attached to the anchor blocks. Recommended spacing is between 12" and 16" O.C."

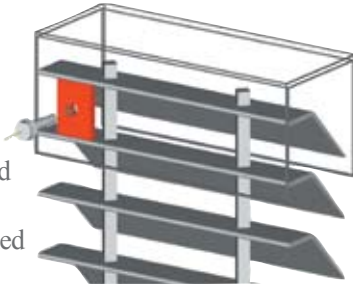

Z-Clip

The most versatile clip anchor available is the Z-Clip. They are especially helpful in holding down riveted grating. Z-Clips are manufactured from stainless steel and are available in 1" (1" & 1-1/4" grating), 1-1/2" (1-1/2" & 1-3/4" grating), and 2" (2", 2-1/4" & 2-1/2" grating) with a pre-punched hole to accept a 1/4" bolt or TEK screw.

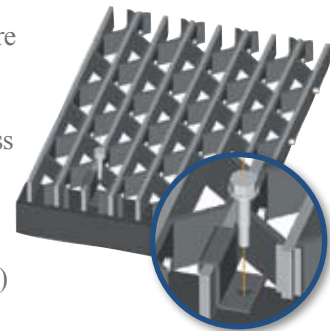

Grating Clamp

A special friction fastener available in aluminum, stainless steel and galvanized steel used in conjunction with bar grating and embedded grating frames.

Note: Cross bars may need to be snipped in the field to facilitate placement of grating clamps.

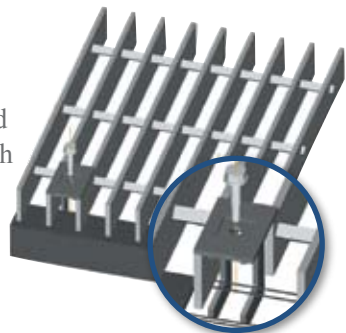

Countersunk Land

For close-mesh aluminum grating (7/16") bearing bar centers, a countersunk land may be drilled by the grating manufacturer for use with a 1/4" dia. TEK screw.

Note: Available for aluminum grating and steel.

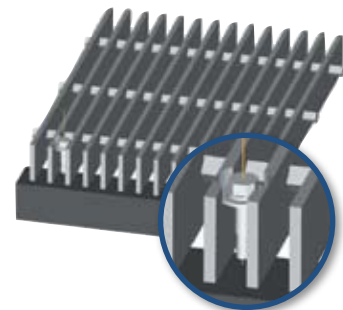

Anchor Block

Anchor blocks of 1/4" or 3/16" thick aluminum or steel may be shop welded by the grating manufacturer and used to fasten permanent or removable grating panels. Anchor blocks are recessed thus offering a trip-free surface.

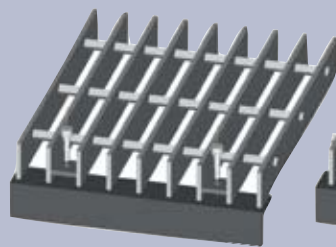

19-SG-4

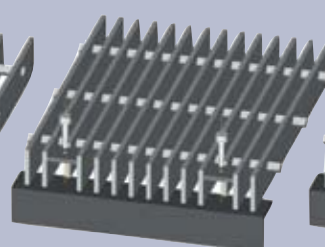

11-SG-4

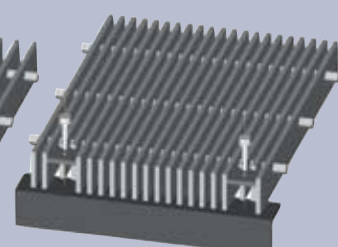

7-SG-4

Note: For ADA compliant spacings, the lug will typically be installed at the top. Tack welding of grating in the field (by others) is also a positive method for anchoring all permanently installed grating.